

EMB Slide Unit Series

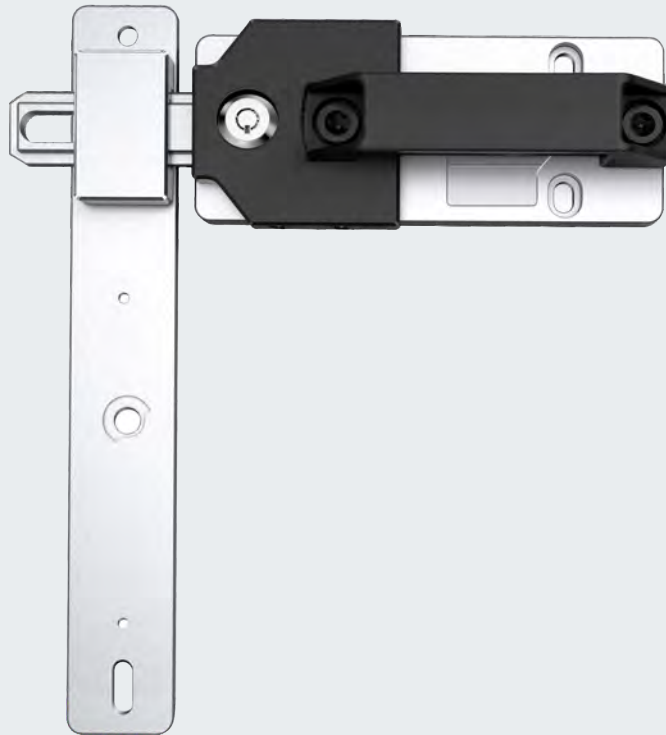

Product Introduction

The safety latch is the ideal complement of safety switch and safety locking device. The accurate guidance of the driving element increases the tolerance in the event of a movement of the latch and always guarantees the proper functioning of the installed safety switch. In addition, the safety latch effectively prevents the driving element from breaking. This eliminates malfunctions and allows a high performances level to be achieved for the overall construction. Additional options such as hinged locks or emergency unlocking devices reliably prevent accidental access by maintenance personnel.

Product Feature

- Reduce cost of development and installation.
- Mechanical protection and AL6063 robust material ensure long life.
- Improving productivity by robust design and sensor.
- Models equipped with emergency unlock device prevent accidental operation.
- Padlock design prevents unintentional entry by workers.

Product Size

EMB-R01

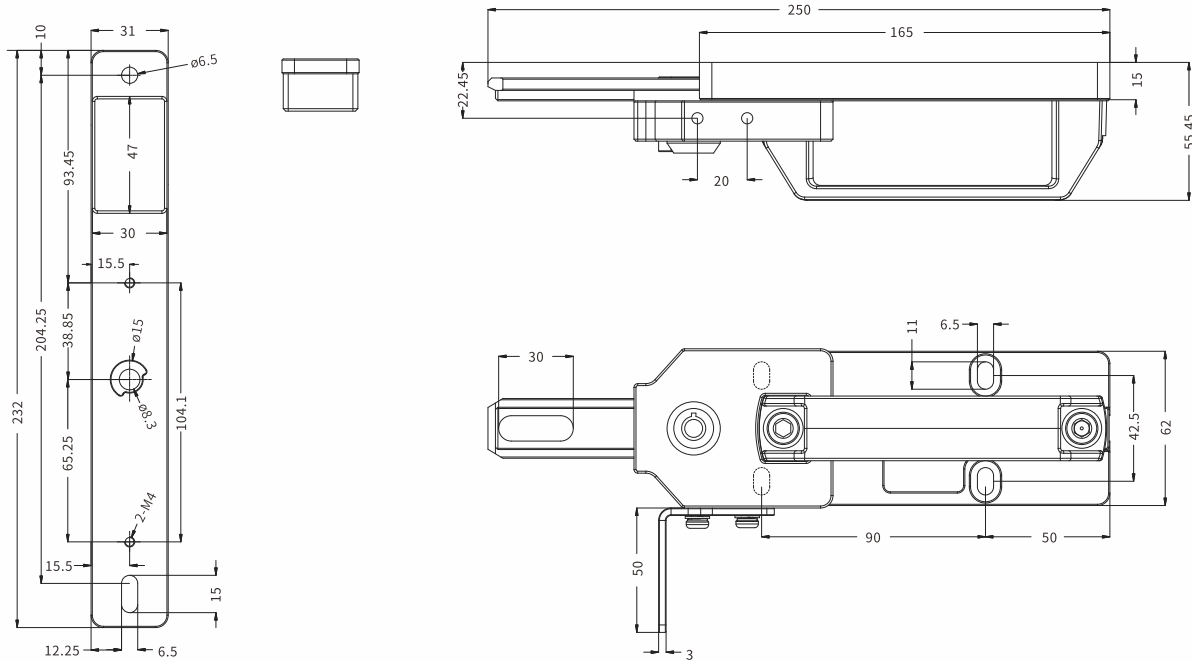

EMB-M02

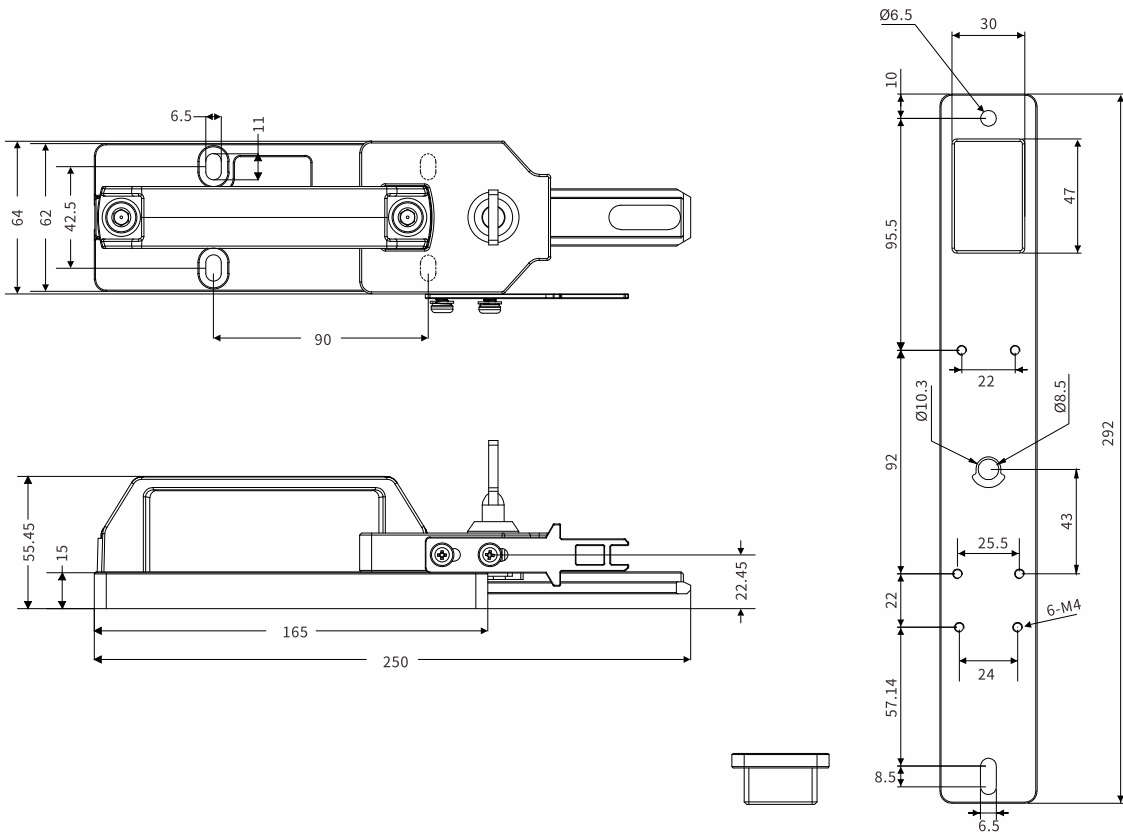

Combination & Model Selection

EMB-R01



SLR11 series



EMB-R01

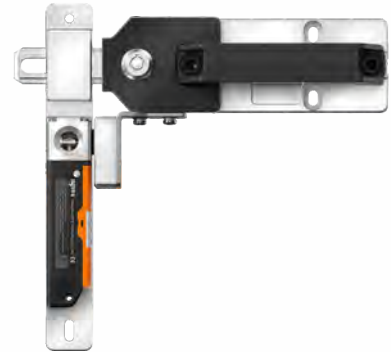

Right slide to open



SLR11 series

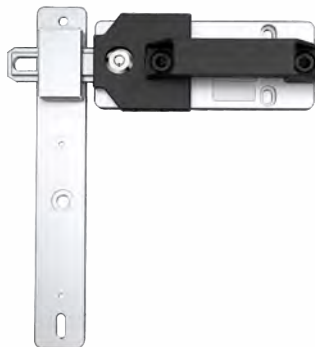

EMB-R01

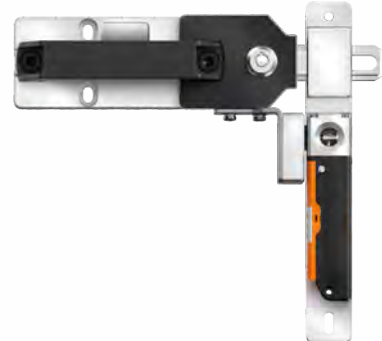

Left slide to open

Remark: Picture is for showing installation, door switch & safety latch should be purchased separately.

EMB Slide Unit Series

EMB-M02

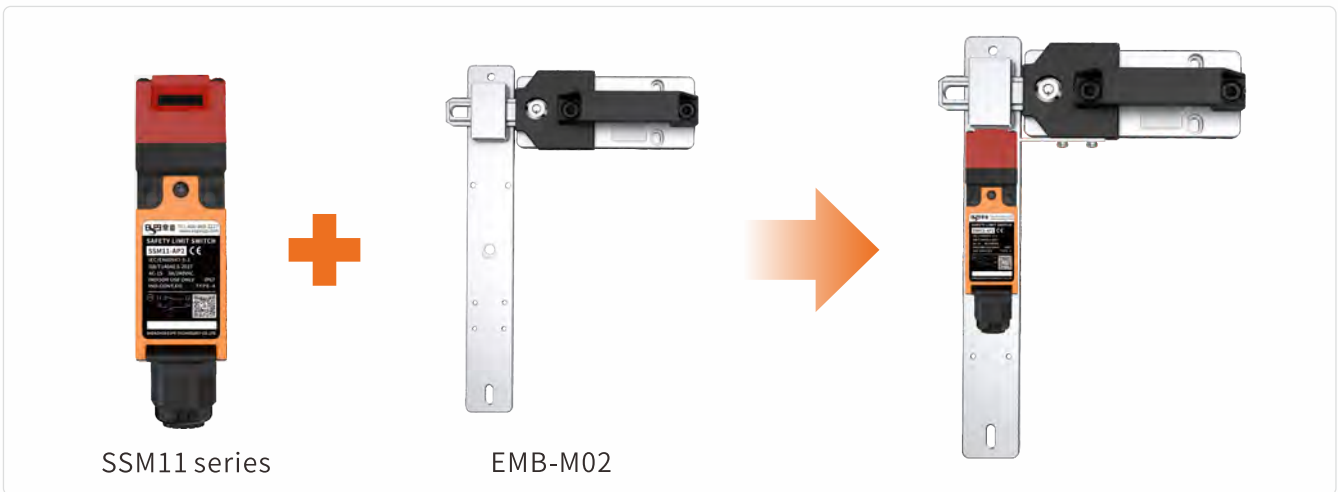
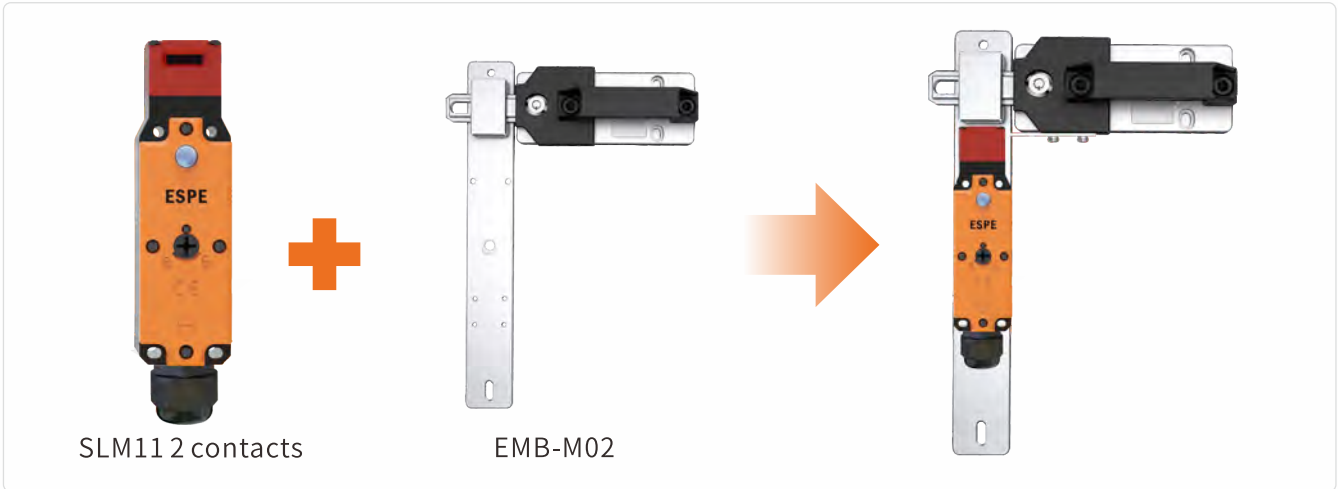

Remark: Picture is for showing installation, door switch & safety latch should be purchased separately.

EMB-M03

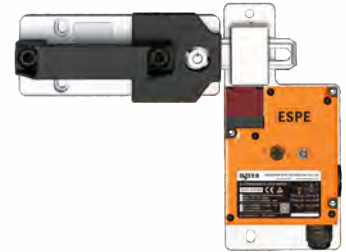
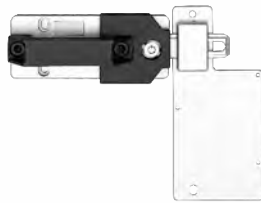

SLM21 series

EMB-M03

EMB-M04

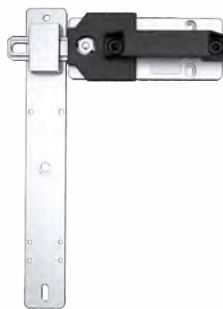

SLM13 series

EMB-M04

Remark: Picture is for showing installation, door switch & safety latch should be purchased separately.